

- ❖ 8 channels
- ❖ 250 MSPS, 14-bit A/D
- ❖ Supports multiple clock and reference configurations
- ❖ Versatile and industry-standard VITA 57.1 FMC
- ❖ Perfect for Lyrtech's μ TCA Perseus AMCs



The MI250 FPGA mezzanine card (FMC) is equipped with eight A/D conversion channels and fully complies with the VITA 57.1 standard. The MI250's eight, 14-bit, 250 MSPS conversion channels can be sampled by an internal clock source (that can be locked onto an external reference) or an external sample clock. A trigger input is also available for customized sampling control.

The MI250 is equipped with a high-pin-count (HPC) connector and front panel I/Os, and is designed around Texas Instruments' ADS62P49 dual-channel, 14-bit, 250 MSPS A/D converter. The analog signal inputs can be AC or DC coupled and they are connected to the SSMC coaxial connectors on the front panel of the card.

The MI250 allows flexible sampling frequency, analog input gain, and offset correction control through serial communications with an AMC. Further, the card is equipped with a power supply and temperature monitoring system, as well as several power-down modes to deactivate unused functions.

Features

- Eight, 14-bit, 250 MSPS A/D conversion channels
- Complies with VITA 57.1
- Designed around the ADS62P49 from Texas Instruments
- Front-panel, coaxial inputs on SSMC connectors
- AC-coupled or DC-coupled analog inputs
- 400-pin, HPC connector
- Flexible clock tree:
 - Internal clock
 - External clock

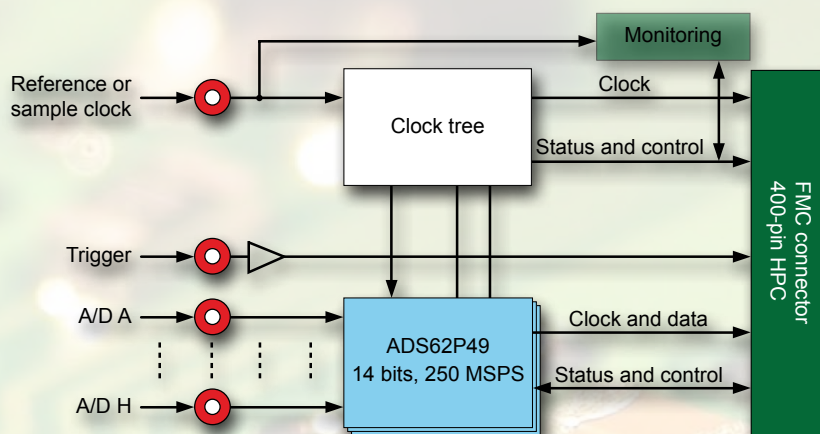

Performance

- AC bandwidth: 700 MHz
- DC bandwidth: 320 MHz
- Crosstalk: 70 dB
- Analog inputs ($1 V_{pp}$ or $2 V_{pp}$): 4 dBm or 10 dBm
- Clock input (typical): 0 dBm
- (LV)TTL compatible trigger
- Programmable gain: 0–6 dB
- Offset correction: ± 10 mV

MI250 performance

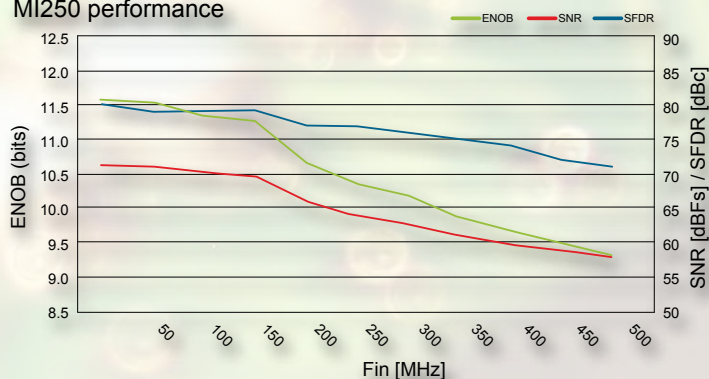

Target applications

- MIMO systems
- Beamforming
- Wireless communication receivers
- Medical imaging (PET, ultrasounds)
- Test measurement instruments
- Scientifics (particle accelerators, astronomy)

Specifications

FMC connectivity

- High pin-count connector
 - LA (00-33), HA (00-23), HB (00-16)
 - CLK0: M2C clock

Front panel

- SSMC connectors
 - A/D channels A-H ×8
 - External trigger
 - External reference/sampling clock input

Mechanical

- Dimensions: 69.0 mm × 15.0 mm × 87.5 mm (W×H×D)
- Rugged FMC form factor — designed for conduction cooling. Contact Lyrtech for details.

Standards compliance

- VITA 57.1

Electrical

- 12 V
- 3.3 V
- 2.5 V (V_{adj})

Power consumption

- 3.3 V power supply: maximum 10 W
- 12 V power supply: maximum 12 W
- 2.5 V (V_{adj}) power supply: maximum 12.3 W

Environmental

- Operating temperature: 0°C to 70°C
- Storage temperature: -50°C to 125°C
- Operating humidity: 0% to 100%, non-condensing
- Storage humidity: 0% to 100%
- Vibration: 0.1 g^2/Hz , 10 Hz to 3 kHz
- Shock: 30 g peak

Purchase information

Phone

(1) 418-877-4644

Toll free in the US and Canada: 1-888-922-4644

E-mail

info@lyrtech.com

Visit us on the Web at www.lyrtech.com.

Lyrtech products are constantly being improved; therefore, Lyrtech reserves itself the right to modify the information herein at any time and without notice.

Lyrtech Incorporated. All rights reserved.

2011-09-14