

RADIO420X

Multimode SDR RF FMC transceiver

- ❖ SISO, dual-band and 2x2 MIMO RF transceivers
- ❖ Wide frequency range — 300 MHz–3 GHz
- ❖ Selectable bandwidth — 1.5–28 MHz
- ❖ Multiple reference configurations and expansion modes
- ❖ Individually shielded RX and TX analog paths
- ❖ Industry-standard, versatile VITA 57.1 FMC



The Radio420X FPGA mezzanine card (FMC) is a powerful multimode SDR RF transceiver module designed around the state-of-the-art, multistandard, multiband Lime Microsystems LMS6002D RF transceiver IC, which supports broadband coverage, as well as TDD and FDD full duplex modes of operation.

The LMS6002D RF transceiver IC's bandwidth (1.5–28 MHz), selectable on-the-fly, makes it suitable for a large number of narrowband and broadband applications with excellent channel selectivity. Combined with multiple references and synchronization modes, the Radio420X is right at home in such applications as multimode software-defined radio (SDR), advanced telecommunications (MIMO systems, cognitive radios, WiMAX, white space, Wi-Fi, GSM, WCDMA), and signal intelligence (SIGINT).

The Radio420X complies with VITA 57.1, a widely used standard in the digital signal processing industry, making it easier for developers to integrate FPGAs into embedded system designs.

The Radio420X is also completely integrated to the Lyrtech μ TCA Perseus AMCs, but it can as easily be used on any FMC carrier on the market. It is compatible with low-pin-count (one RF transceiver) and high-pin-count (two RF transceivers) FMC interfaces.

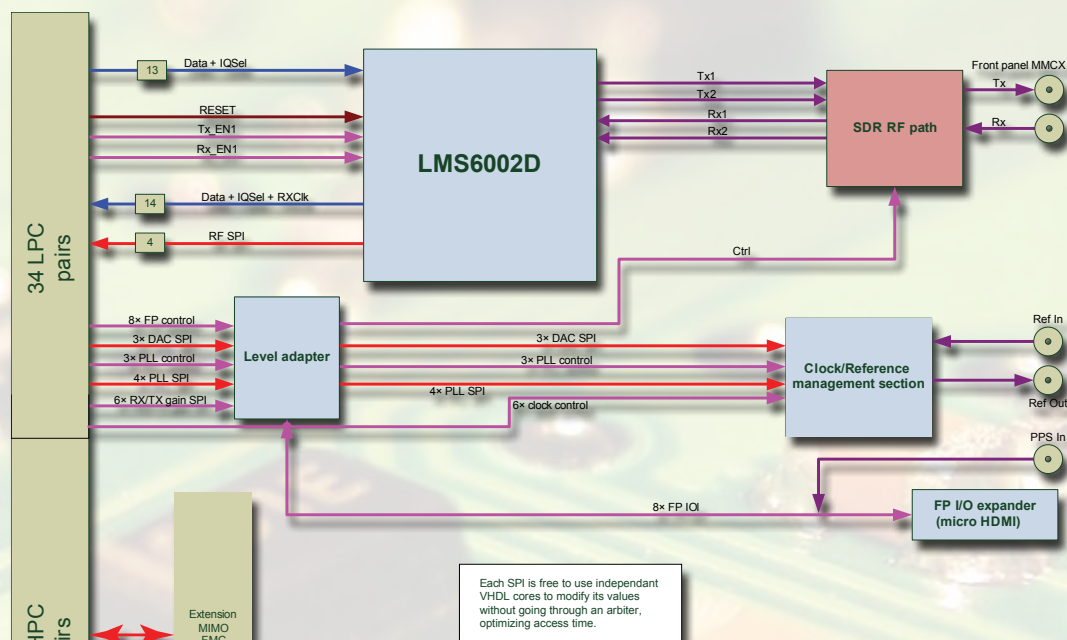

Hardware architecture

The VITA 57.1 standard comes to the rescue of complex designs with its unprecedented mechanical and electrical flexibility. It offers standard specifications for small, mezzanine modules designed to adapt an FPGA-based carrier card to different I/O requirements.

Features

The Radio420X features:

- 300 MHz–3 GHz RF frequency range
- 1.5–28 MHz programmable modulation bandwidth
- FMC LPC — one RF transceiver

- FMC HPC — two RF transceivers. See specifications for details.
- Maximum 10 dBm output power
- TBD dBm input sensitivity
- Over 80 dB software-programmable RX/TX analog dynamic range
- Separate TX and RX antennas on the front panel
- Software-selectable RX filters bank (for standard wireless applications) and full-bandwidth option
- Selectable reference input — onboard, front panel, or FMC driven
- Reference output on front panel for synchronized multiboard/multichannel [MIMO] applications
- Equipped with an onboard, low-jitter reference clock, cross-point switch, and synchronization PLL
- Front panel I/O expander for external control (such as interfacing to an external TX PA)
- Shielded for noise immunity

Analog SDR RF paths (with selectable RX filter banks)

The Radio420X's RX and TX analog paths are designed to offer the best versatility-to-performance ratio, addressing the high demands of multimode RF applications.

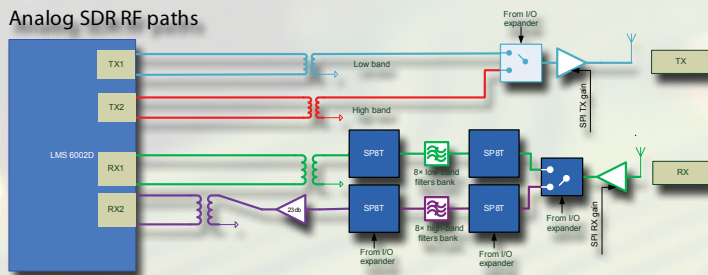

At the transmitter end, a software RF switch is used to select the low-band TX1 output or the high-band TX2 output of the LMS6002D. This switch is followed by a 6-bit, 4 GHz broadband amplifier where the gain can be adjusted between -13.5 dB and 18 dB, on top of the integrated LMS6002D's TX VGAs, yielding a maximum output power of 10 dBm.

At the receiver end, a similar 6-bit, 4 GHz broadband amplifier is present on top of the integrated LMS6002D's RX VGAs (minimum signal sensitivity of TBD dBm). The amplifier is followed by a software-selectable switch that enables the LMS6002D's low-band RX1 path or the high-band RX2 path. Each RX path has eight software-selectable filter banks. The table below describes the filter banks on each path.



Filter	RX1 low band	RX2 high band
1	UMTS and LTE band I (downlink)	UMTS and LTE band V/ GSM850 (downlink)
2	UMTS and LTE band I (uplink)	UMTS and LTE band V/ GSM850 (uplink)
3	Micro-coax connection for custom user filters or pass-through (optional)	
4	UMTS and LTE band II/ PCS1900 (downlink)	UMTS and LTE band VIII/ EGSM900 (downlink)
5	UMTS and LTE band II/ PCS1900 (uplink)	UMTS and LTE band VIII/ EGSM900 (uplink)
6	ISM900—26 MHz bandwidth	WiMAX (2.4–2.5 GHz), Wi-Fi a-n, Bluetooth, ZigBee, ISM bands
7	LTE band 13 (downlink)	DCS1800 (downlink)
8	LTE band 13 (uplink)	DCS1800 (uplink)

Clock management facility

The Radio420X's clock management facility is designed around the CDCE62005 from Texas Instruments, which offers low-phase-noise clock distribution, a PLL core, dividers, dual VCOs, and a jitter cleaner feature. Combining the clock management facility to a very-low-jitter, 4x4 crosspoint switch makes it possible to generate a variety of clocks necessary to the Radio420X. The reference clock can be generated on the FMC, through its carrier or through the front panel external reference input. The selected reference clock is available on the front-panel reference output and is supplied to the FMC carrier.

A PPS signal can also be sent to the carrier's FPGA to dynamically adjust the Radio420X's onboard VCXO through a programmable DAC — something especially useful when a GPS-disciplined clock is needed to drive reference clocks. For details about the GPS-disciplined FPGA core, contact Lyrtech at info@lyrtech.com.

While the Radio420X natively supports 2x2 MIMO (Radio420M), feeding a common reference clock to several units makes it possible to expand to 4x4 and beyond.

SISO and 2x2 MIMO configurations

The Radio420S (S for SISO) complies with all the electrical and mechanical specifications of VITA 57.1, making it possible to use on any FMC-compliant carrier on the market. On Lyrtech's Perseus AMC, it fits in a mid-size μ TCA slot.

In 2x2 MIMO mode, a Radio420S and Radio420E (essentially a Radio420S with an extra HPC) are stacked to become the Radio420M (M for MIMO). The Radio420M complies with all the electrical specifications of VITA57.1, but the height of the module fails to comply with the mechanical specifications. An additional 10 mm in height must therefore be allotted when using the Radio420M on



an FMC carrier other than a Lyrtech Perseus AMC. On Lyrtech's Perseus AMC, it fits in a full-size μ TCA slot.



Performances

Transmitter

- Maximum output (typical): 10 dBm

Specifications

General

- RF range: 300–3000 MHz
- Number of channels: 1
- Channel resolution: 12 bits
- Input voltage range: $1 V_{pp}$

Reference clock

- Tunable, 30.72 MHz, temperature-compensated oscillator

Programmable modulation bandwidths

- 1.50 MHz
- 1.75 MHz
- 2.50 MHz
- 2.75 MHz
- 3.00 MHz
- 3.84 MHz
- 5.00 MHz
- 5.50 MHz
- 6.00 MHz
- 7.00 MHz
- 8.75 MHz
- 10.00 MHz
- 12.00 MHz
- 14.00 MHz
- 20.00 MHz
- 28.00 MHz

FMC connectivity

Radio420S

- Low-pin-count connector
 - LA (00–32)
 - CLK0 (required), CLK1 (optional): M2C clocks

Radio420E

- Low-pin-count connector
 - LA (00–32)
 - CLK0 (required), CLK1 (optional): M2C clocks
- High-pin-count connector
 - LA (00–32), HA (00–18), HB(00–14)
 - CLK0 (required), CLK1 (optional): M2C clocks
 - CLK2, CLK3 (both optional): C2M clocks

Radio420M

- High-pin-count connector
 - LA (00–32), HA (00–18), HB(00–14)
 - CLK0 (required), CLK1 (optional): M2C clocks
 - CLK2, CLK3 (both optional): C2M clocks

Front panel MMCX connectors

Radio420S and Radio420E

- RF TX
- RF RX
- External reference input
- External reference output
- PPS input
- Micro-HDMI (8-bit, LVCMOS user I/O)

Radio420M

Double the Radio420S I/Os

Mechanical

Rugged FMC form factor — designed for conduction cooling, but not tested or implemented. Contact Lyrtech at info@lyrtech.com for details.

Radio420S

- Dimensions (W×H×D): 69 mm × 10 mm × 84 mm

Radio420E

- Dimensions (W×H×D): 69 mm × 15.4 mm × 84 mm

Radio420M

- Dimensions (W×H×D): 69 mm × 20 mm × 84 mm

Standards compliance

Radio420S

- VITA 57.1

Radio420E

- VITA 57.1 electrical specifications
- Out of mechanical specifications by H=5.4 mm

Radio420M

- VITA 57.1 electrical specifications
- Out of mechanical specifications by H=10 mm

Electrical

- 12 V
- 3.3 V
- V_{adj} to 2.5 V necessary to power Radio420X ICs

Power consumption

- 6.00 W on 12 V
- 0.50 W on V_{adj} (2.5 V)
- 0.05 W on 3.3 V MP

Purchase information

Phone

(1) 418-877-4644

Toll free in the US and Canada: 1-888-922-4644

Fax

(1) 418-877-7710

E-mail

info@lyrtech.com

Visit us on the Web at www.lyrtech.com.

Lyrtech products are constantly being improved; therefore, Lyrtech reserves itself the right to modify the information herein at any time and without notice. The FMC logo is a trademark of VITA.

Lyrtech Incorporated. All rights reserved.

2011-10-17